

CNC Double Column Machining Center
Crossrail SCR Series

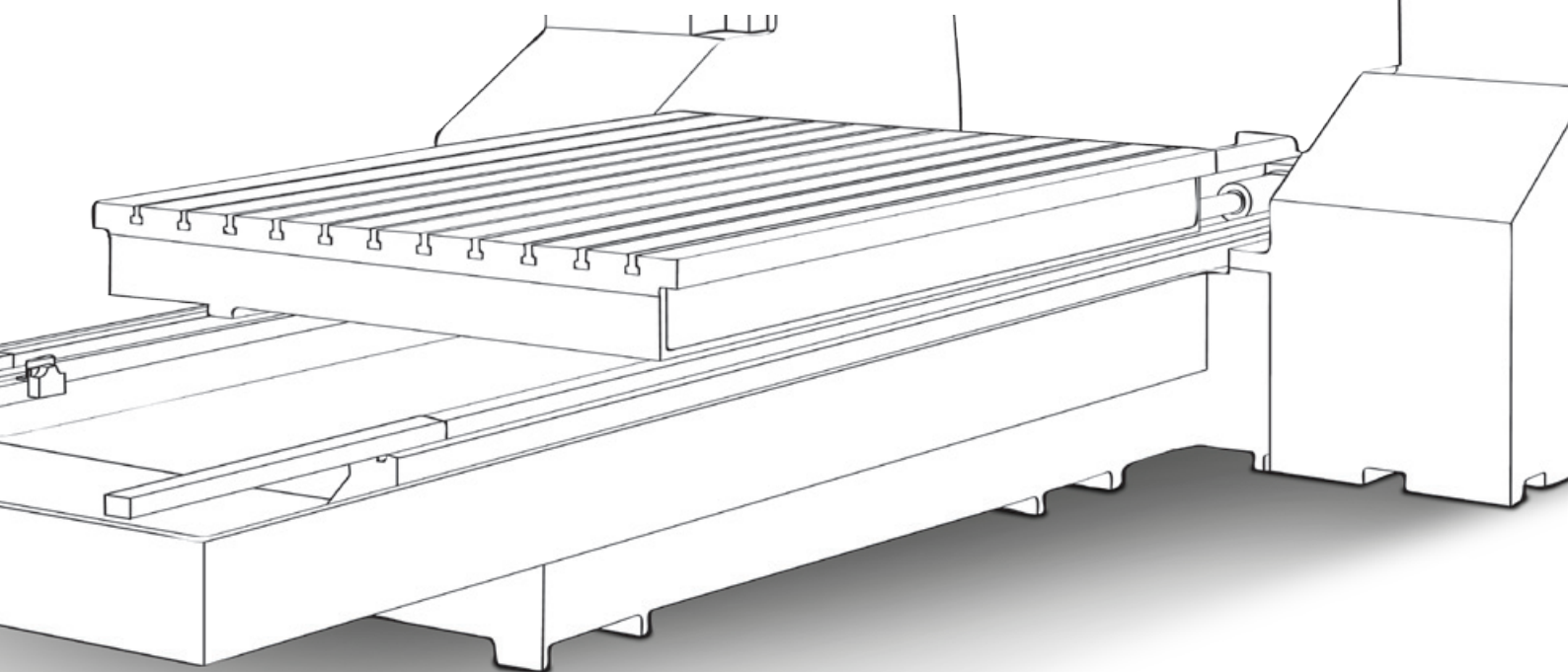

Features

Crossrail Double Column Machining Center

Excellent Construction Design & Massive Functionality



Closed-Circuit Hydraulically Balanced Design

Controls Z- and W-axis movement.

Adv.: Provides accuracy, stability and energy savings.

Powerful Clamping Mechanism for W-axis

W-axis clamping mechanism uses a disc spring locking technique (normally closed). During W-axis movement hydraulics open the clamping mechanism and after positioning they automatically lock.

Adv.: Lock not affected by cutting vibration, also saves energy.

Design for the Rails of W-axis

The rails of W-axis are Box-Way, and increase the distance of rails to raise the area of moments.

Adv.: Powerful rigidity and good shock-absorbing effect.

Also, it is convenient for the adjustment of accuracy.

Safety Railing Design

All models have a safety railing design.

Adv.: Ensures the safety of maintenance staff, also allows for easier machine repair.



Special Lift Mechanism Design for Swing Type Revolving Control Box

Hydraulic lift collocates with linear guideway to ensure stable movement of revolving control box.

Adv.: Height of control box can be adjusted at any time to suit the needs of the operator.

Patent

M301099	Machine Tool Spindle Ram Steady Movement Mechanism 2
M381480	Stable Saddle Structure for Machine Tools
M346487	Drive Eliminating Backlash Mechanism for Machine Tool
M349310	Auto Attachment Head Change Clamping Device for Machine Tool
M469977	The Adjustment Mechanism of Column for Double Column Machining Center

High Rigidity | High Accuracy | High Efficiency | High Stability

Application



Contents	Features	Construction	Spindles & Options	HMI & ATC	Lay-out & Table Dimensions	Machine Specifications
	1-2	3-6	7-8	9-10	11-12	13-14

Construction

Behind the beam there is a double closed-circuit hydraulic balance unit to ensure stability and accuracy during beam movement and positioning.

W Axis

W-axis up and down movement is powered by a twin servo motor with gear reducer.

Standard Travel
1400 mm

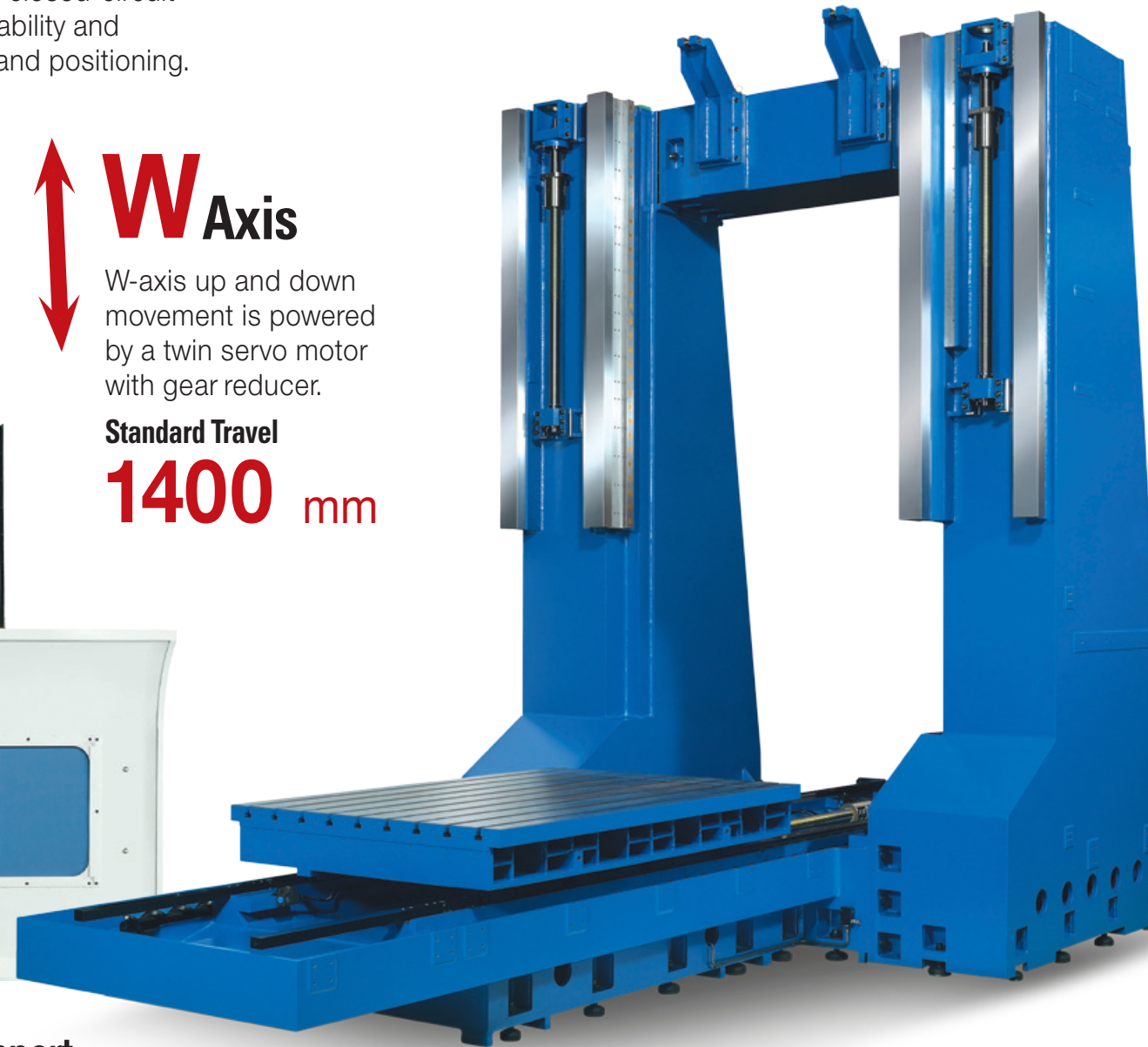
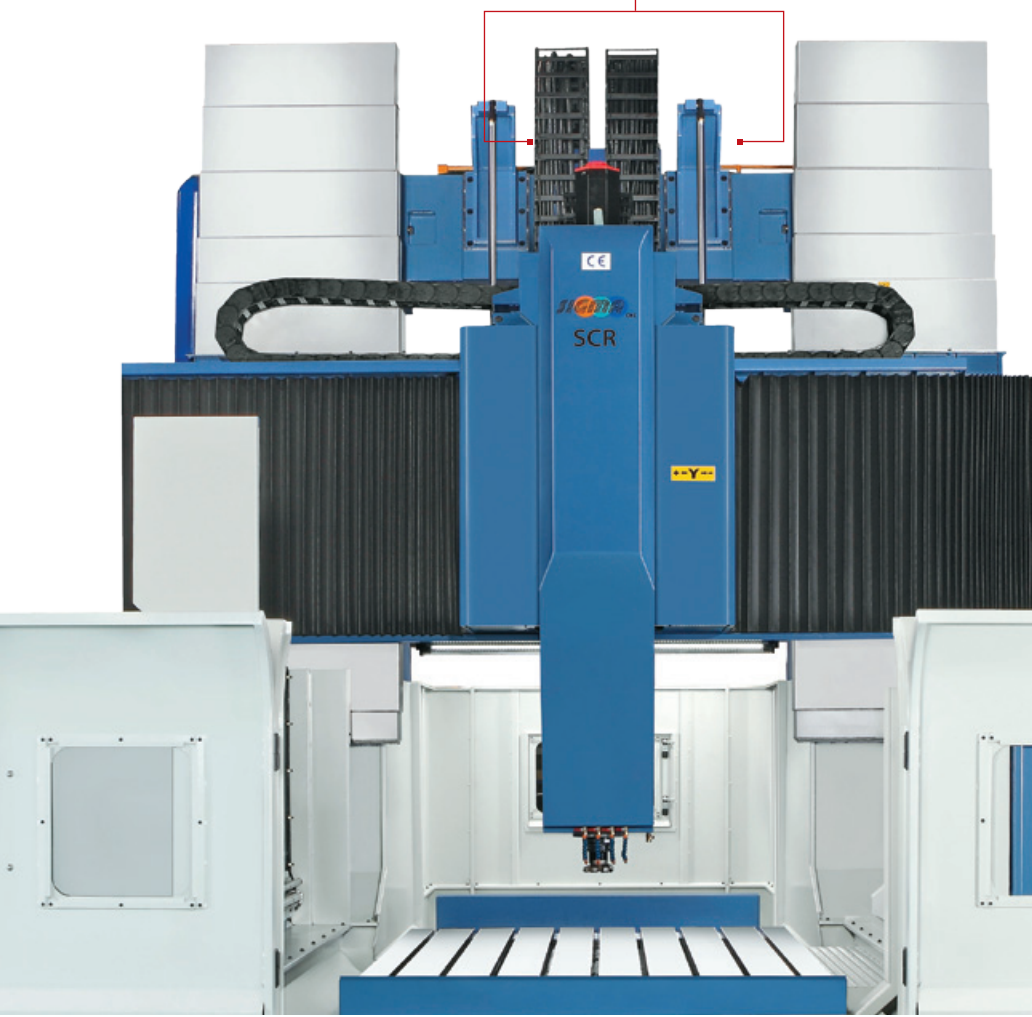

Super Column Design with Box-way W-axis

W-axis features a very wide and stable box-way for stable movement. The box-way has been surface treated and precisely ground, to ensure optimum material hardness and accuracy. This provides high precision movement and a longer W-axis life.

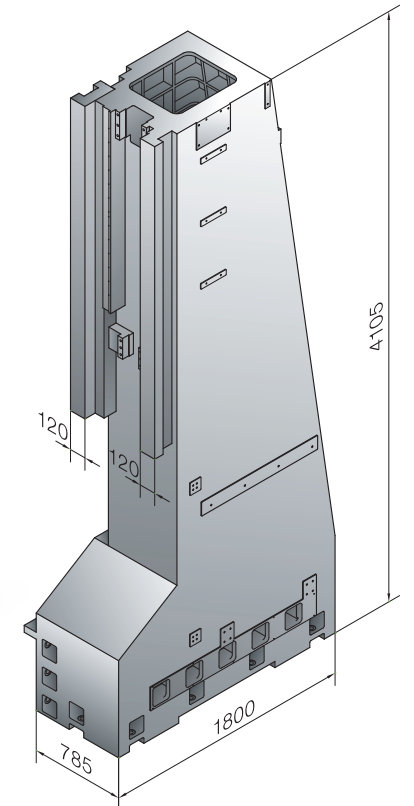

Y-axis Ball Screw Support

Features a Y-axis link-type ball screw support. This reduces ball screw run out and vibration during fast movement. Also increases the stability and life of the ball screw.

X-axis Ball Screw Support

Features a pneumatic unit that collocates with several cylinder-type supports, to provide suitable support of the X-axis ball screw. This increases the stability and life of the ball screw.

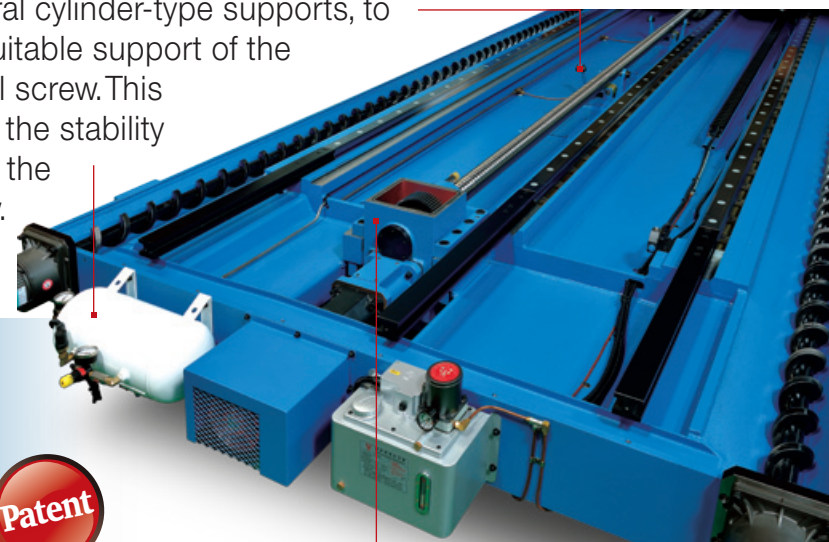

Patent

X-axis Free Backlash Transmission Gearbox, Made by SIGMA CNC. Offers quick reactions without hysteresis. Also features a special mechanism that minimizes backlash and increases movement precision.

Powerful Clamping Mechanism for W-axis

- During travel, the W-axis can move to any position and then be locked using the powerful clamping mechanism.
- The powerful clamping mechanism provides greater rigidity, stability and therefore results in precision machining.

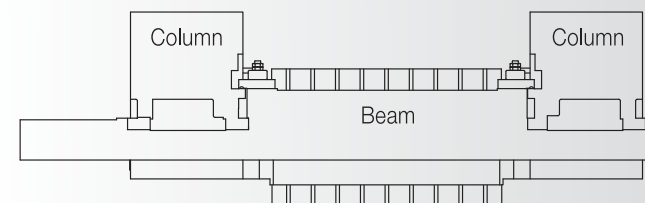
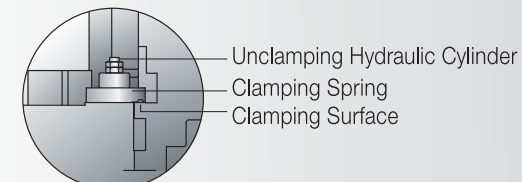

Special Adjustable Mechanism between Column & Base

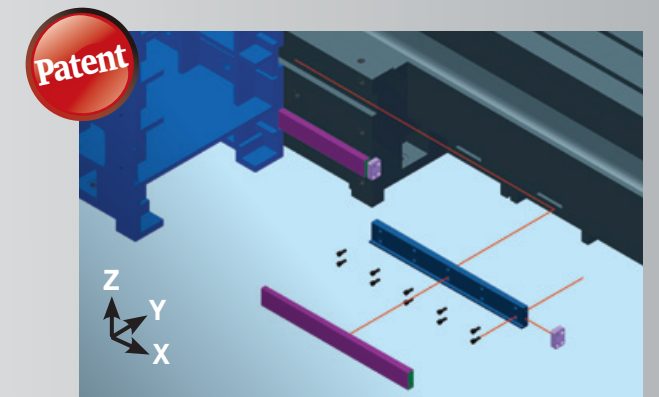

Patent

This provides accurate adjustment between column and base increasing machine stability.

Construction

SCR-H Series Spindle Ram

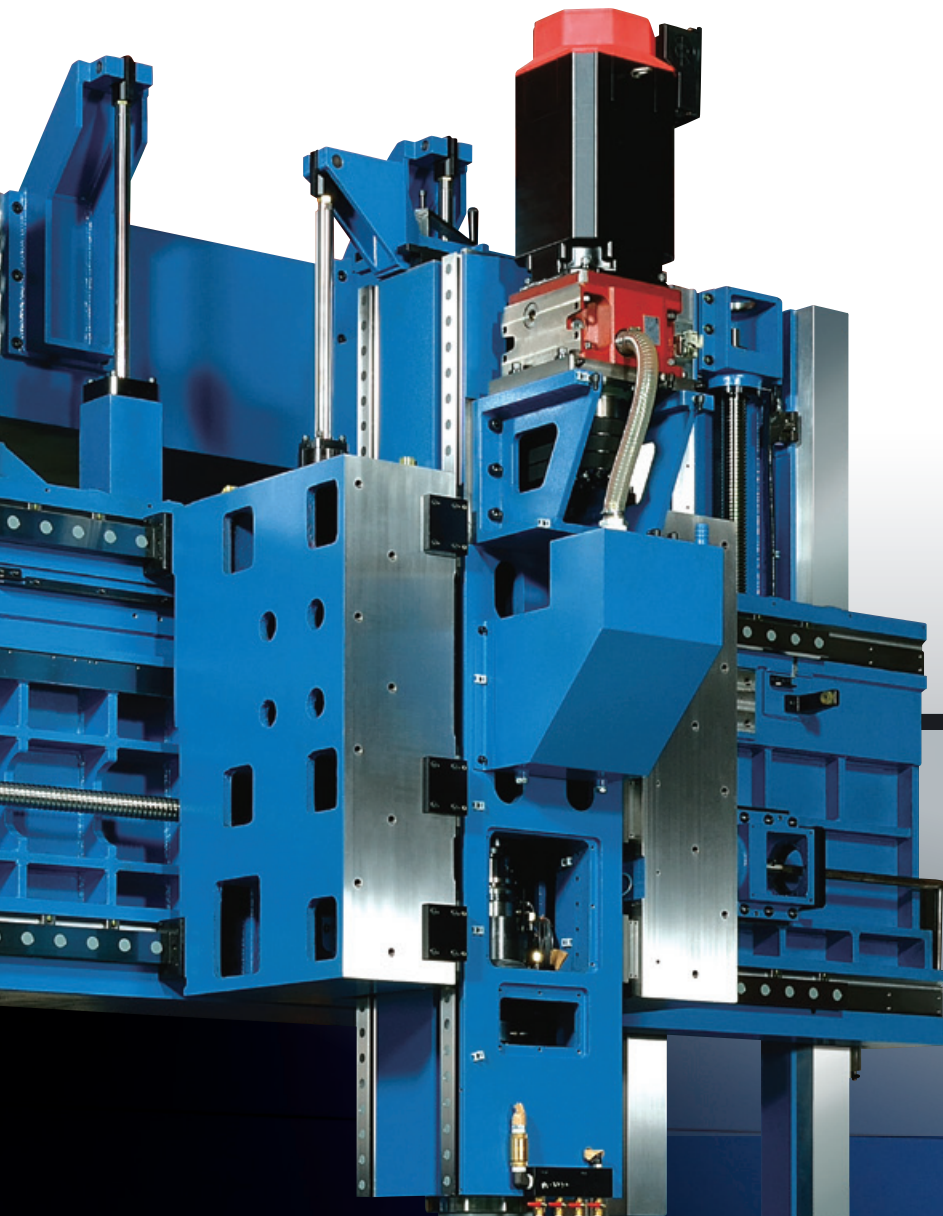

Spindle Ram is Supported by Four Linear Guideways

Z-axis uses Four Roller-type Linear Guideways (THK SRG45).

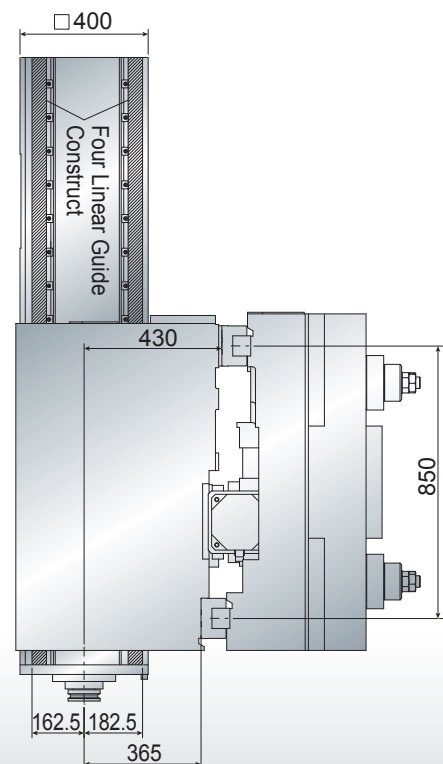

SCR-VH

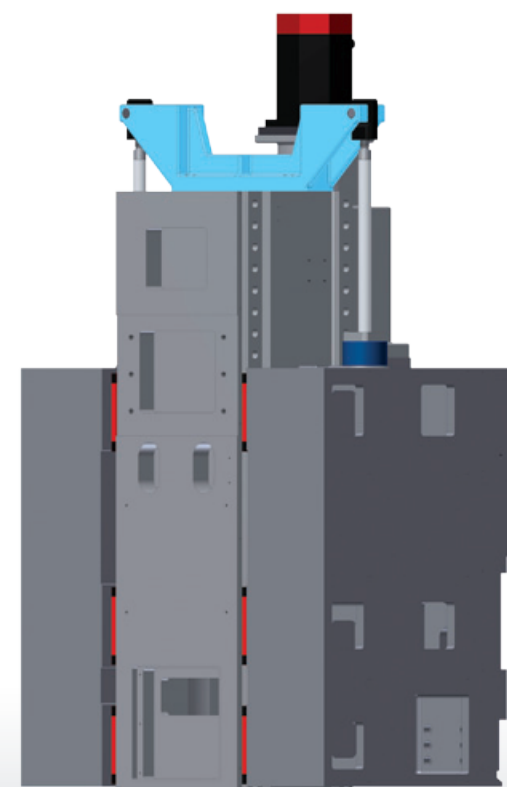

SCR-HLA

SCR-H

Z-axis uses Four Linear Guideways



V&H Universal Head Model (Max. 3500 rpm)



Auto Attachment Head Change Model

For all Machine Models We offer Three Types of Spindle

- Belt Drive Spindle with 2-steps Planetary Gearbox (4,000/ 6,000/ 8,000 rpm)
- Direct Drive Spindle (8,000/ 10,000 rpm)
- Direct Drive Spindle with 2-steps Planetary Gearbox (6,000/ 8,000/ 10,000 rpm)

Contact Us for More Details

Spindles

Spindle Drive Mechanism & Spindle Speed

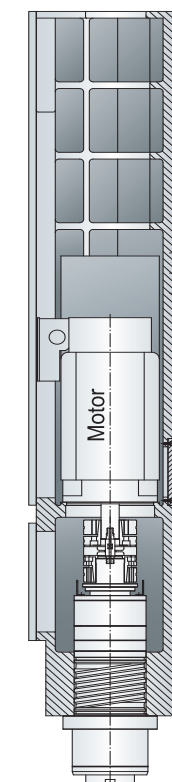

Direct-drive Spindle Mechanism (8,000/ 10,000 rpm)

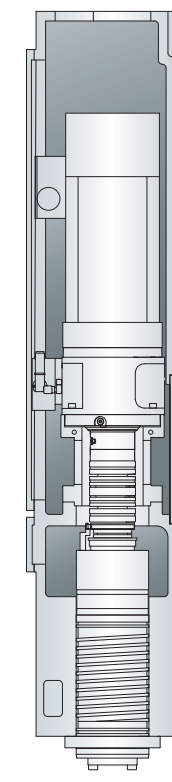

Direct-drive Spindle with 2-steps Planetary Gearbox (6,000/ 8,000/ 1,000 rpm)

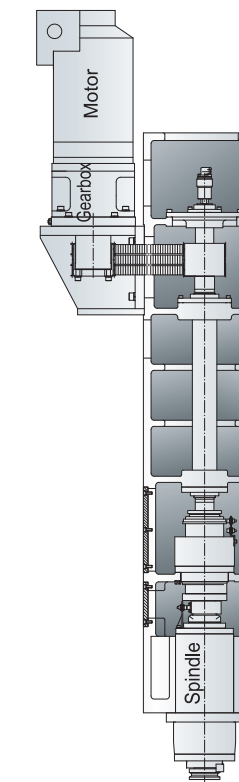

Belt-drive Spindle with 2-steps Planetary Gearbox (4,000/ 6,000/ 8,000 rpm)

Spindle Torque Diagrams

Belt Drive Spindle

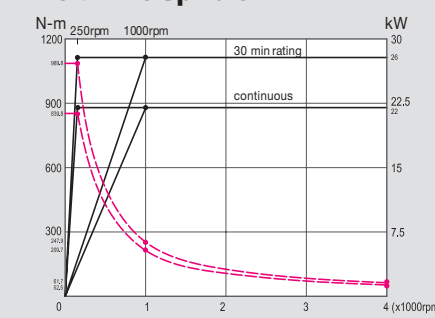

α 22 Motor 26/ 22 kW BT-50 Spindle 4,000rpm Output Power & Torque Characteristic RATE: (1:6, 1:1.5) with 2-steps Planetary Gearbox

Belt Drive Spindle

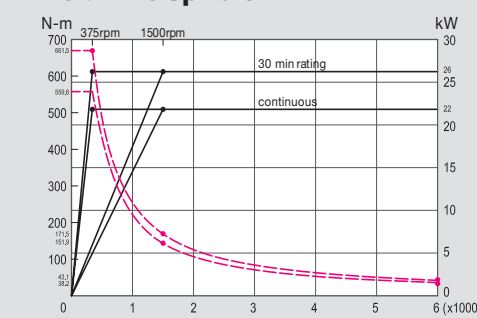

α 22 Motor 26/ 22 kW BT-50 Spindle 6,000rpm Output Power & Torque Characteristic RATE: (1:4, 1:1) with 2-steps Planetary Gearbox

Direct-drive Spindle with Gearbox

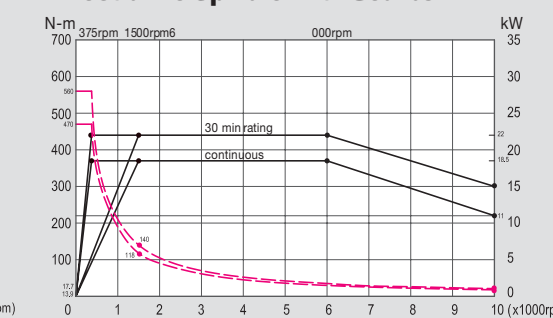

α 18 Motor 26/ 18.5 kW BT-50 Spindle Max. 10,000rpm Output Power & Torque Characteristic RATE: (1:4, 1:1) with 2-steps Planetary Gearbox Direct Drive

Direct-drive Spindle with Gearbox

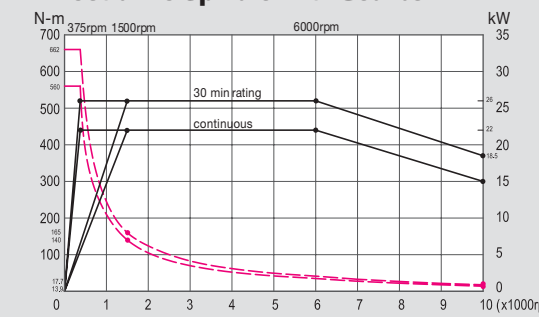

α 22 Motor 26/ 22 kW BT-50 Spindle Max. 10,000rpm Output Power & Torque Characteristic RATE: (1:4, 1:1) with 2-steps Planetary Gearbox Direct Drive

Direct-drive Spindle with Gearbox

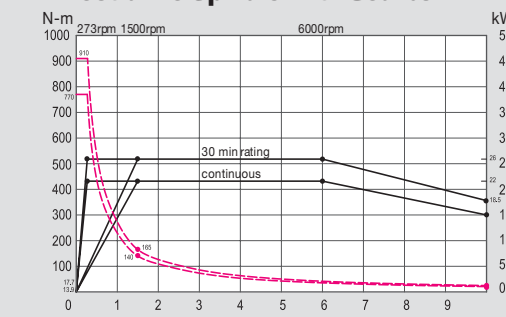

α 22 Motor 26/ 22 kW BT-50 Spindle Max. 10,000rpm Output Power & Torque Characteristic RATE: (1:5.5, 1:1) with 2-steps Planetary Gearbox Direct Drive

Optional Milling Heads For SCR-H type (Manual)

Manual 45° Angular Head

C-axis 5 manual indexing / manual tool locking
 Max. spindle speed: 3000 rpm
 Max. output power: 26Kw (35HP)
 Reduction ratio: 1:1
 Spindle taper: ISO#50
 Max. tool diameter: 215
 C.T.S.: Unavailable
 A.T.C.: Unavailable

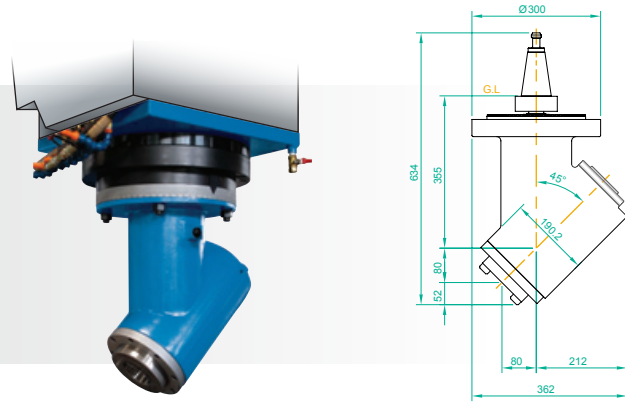

Manual / Semi-auto 90° Angular Head

C-axis auto indexing / hydraulic auto tool clamping
 Max. spindle speed: 3000 rpm
 Max. output power: 26Kw (35HP)
 Reduction ratio: 1:1
 Tool clamping force: 1100 kgs
 Spindle taper: ISO#50
 Max. tool diameter: 215
 C.T.S.: available
 A.T.C.: Unavailable

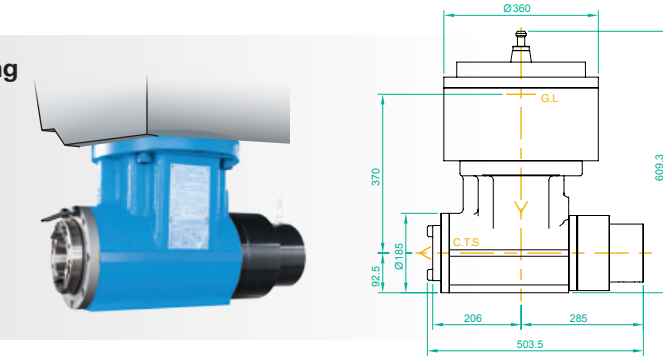

Manual 90° Angular Head

C-axis 90 manual orientation or 5 manual indexing / manual tool locking
 Max. spindle speed: 3000 rpm
 Max. output power: 26Kw (35HP)
 Reduction ratio: 1:1
 Spindle taper: ISO#50
 Max. tool diameter: 215
 C.T.S.: Unavailable
 A.T.C.: Unavailable

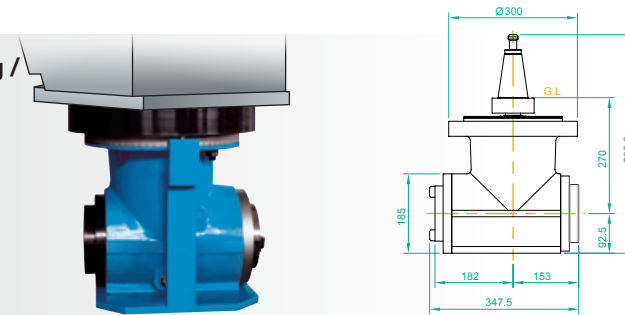

Manual / Semi-auto Swing Divided Angle Head

C-axis 5 manual indexing , A-axis manual 1 rotation / hydraulic manual tool clamping
 Max. spindle speed: 3000 rpm
 Max. output power: 26Kw (35HP)
 Reduction ratio: 1:1
 Spindle taper: ISO#50
 Max. tool diameter: 215
 C.T.S.: Unavailable
 A.T.C.: Unavailable

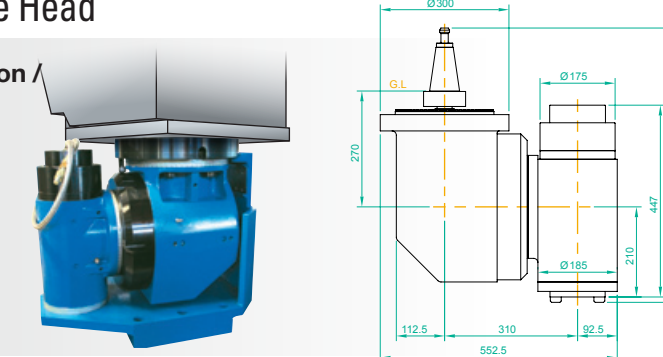

Manual Extension Head 360/560mm

Hydraulic manual tool clamping
 Max. spindle speed: 3000 rpm
 Max. output power: 26Kw (35HP)
 Reduction ratio: 1:1
 Tool clamping force: 1100 kgs
 Spindle taper: ISO#50
 Max. tool diameter: 215
 C.T.S.: Unavailable
 A.T.C.: Unavailable

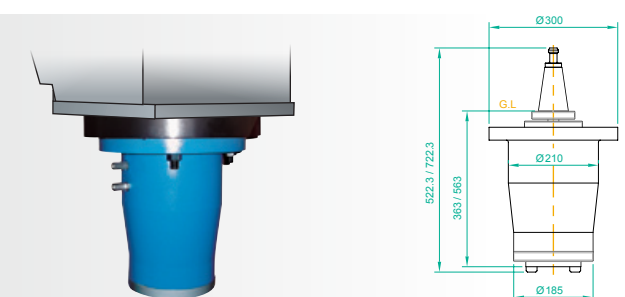

Optional Milling Heads For SCR-HLA type (Auto Attachment Change)

35° Angular Head

C-axis 1° or 5° auto indexing / hydraulic auto tool clamping
 Max. spindle speed: 3000 rpm
 Max. output power: 26Kw (35HP)
 Reduction ratio: 1:1
 Tool clamping force: 1100 kgs
 Spindle taper: ISO#50
 Max. tool diameter: 215
 C.T.S.: Unavailable
 A.T.C.: Unavailable

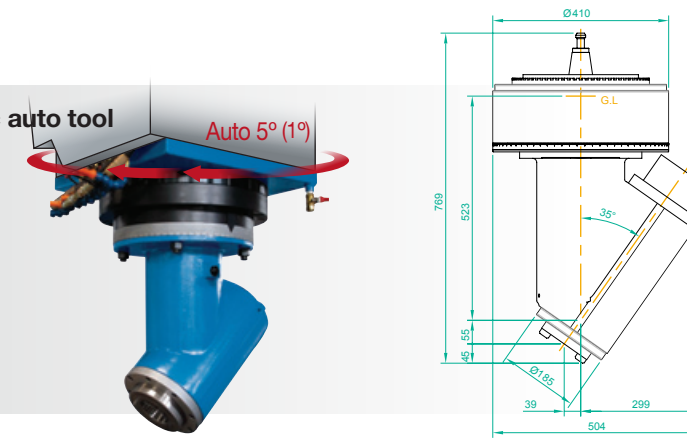

90° Angular Head

C-axis auto indexing / hydraulic auto tool clamping
 Max. spindle speed: 3000 rpm
 Max. output power: 26Kw (35HP)
 Reduction ratio: 1:1
 Tool clamping force: 1100 kgs
 Spindle taper: ISO#50
 Max. tool diameter: 215
 C.T.S.: optional
 A.T.C.: optional

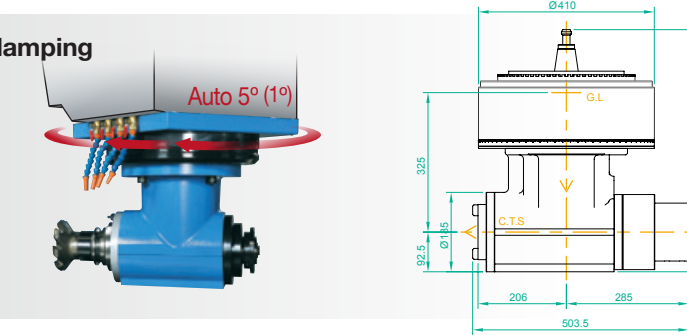

Swing Divided Angle Head

C-axis 1° or 5° auto indexing , A-axis 1° or 5° auto indexing / hydraulic auto tool clamping
 Max. spindle speed: 3000 rpm
 Max. output power: 26Kw (35HP)
 Reduction ratio: 1:1
 Tool clamping force: 1200 kgs
 Spindle taper: ISO#50
 Max. tool diameter: 215
 Max. tool weight: 12kg
 C.T.S.: Unavailable
 A.T.C.: optional

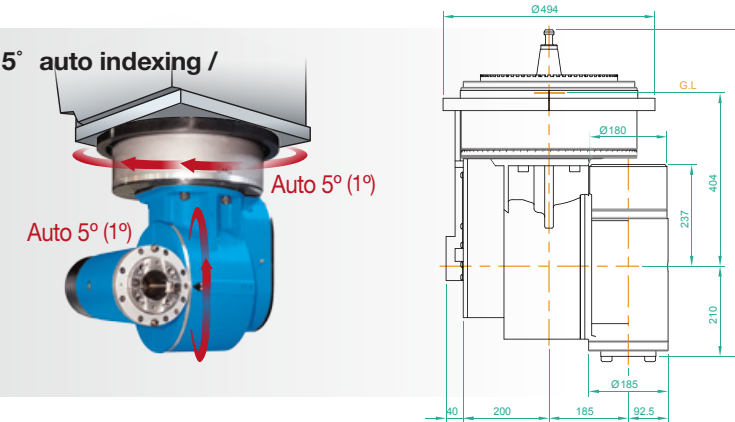

Extension Head 360/560mm

Hydraulic auto tool clamping
 Max. spindle speed: 5000 rpm
 Max. output power: 26Kw (35HP)
 Reduction ratio: 1:1
 Tool clamping force: 1100 kgs
 Spindle taper: ISO#50
 Max. tool diameter: 215
 C.T.S.: Unavailable
 A.T.C.: optional

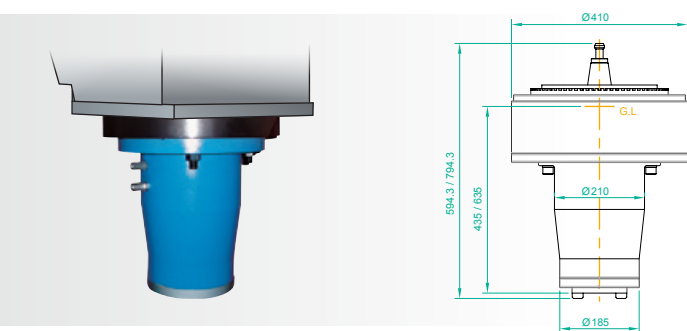

Special Options

Auto Attachment Head Change System

All Heads Made by SIGMA CNC
 Contact US for More Details on Available Heads

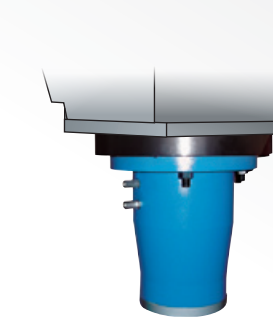

Extension Head
 max. 4,500 rpm
 (360/ 560 mm)

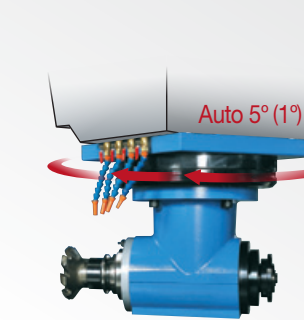

90° Angular Head
 max. 3,000 rpm
 (Available Auto Tool Changing)

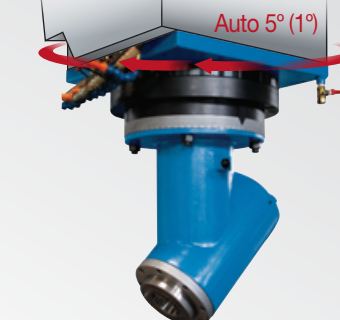

35°, 45° Head
 max. 3,000 rpm

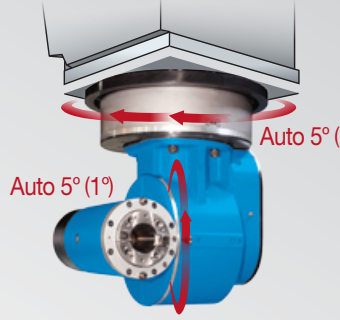

Swing Divided Angle Head
 max. 3,000 rpm (Available Auto Tool Changing)

Multiple Heads Compartment

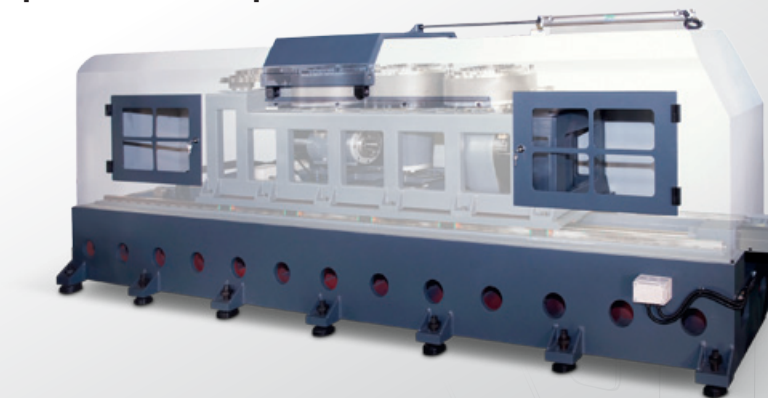

Automatic Compartment Types for Heads

1. Column-type Head Compartment contains 1 Head.
2. Multiple Head Compartment contains more than 2 Heads.
3. Table-type Head Compartment contains 1-3 Heads Only.

Manual Head Supporter



Manual Heads

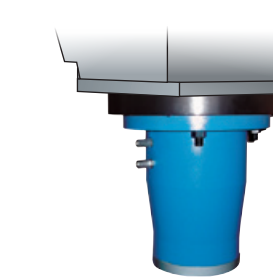

Extension Head
 max. 4,500 rpm
 (360/ 560 mm)

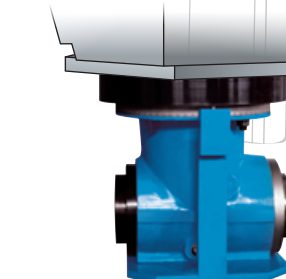

90° Angular Head
 max. 3,000 rpm

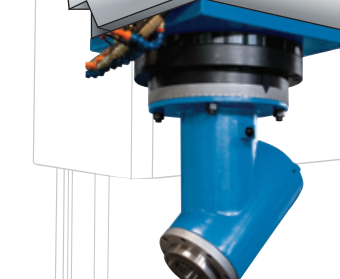

35°, 45° Head
 max. 3,000 rpm

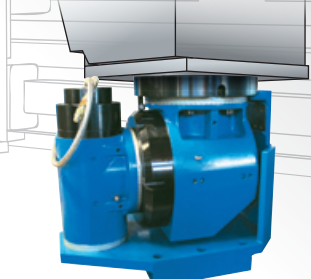

Swing Divided Angle Head
 max. 3,000 rpm

Human Interface

Easy to Operate Graphical Interface **SIMAGE** Made by SIGMA CNC

Intuitive positioning of the W-axis with points and compensation settings. Also simultaneously monitors signal status.

Convenient manual workpiece measurement. No hardware required.

Manual tool length settings easily match operator requirements. Freedom to choose the direction of the axis and retrieve machine coordinates.

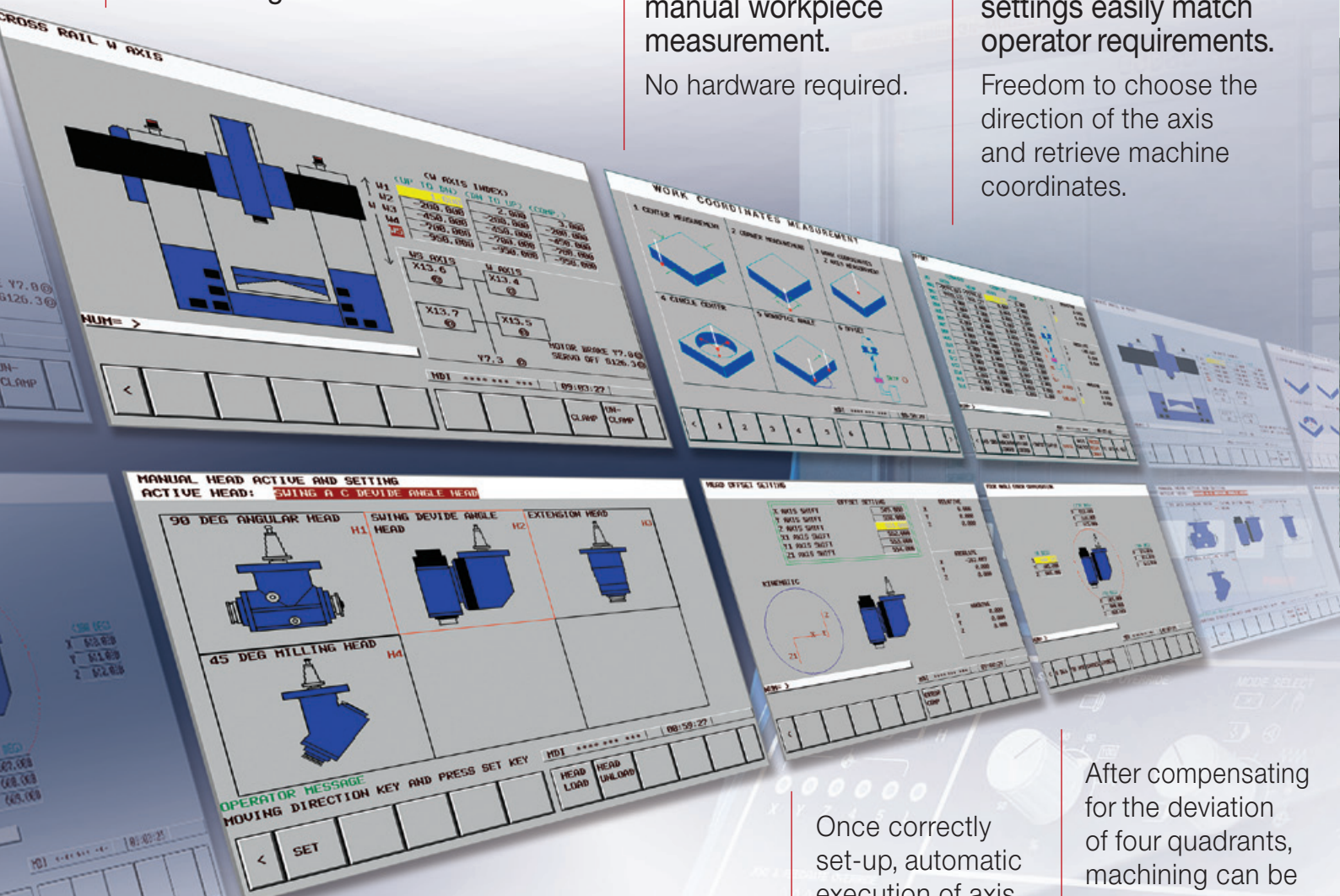

Compensation mechanism accurately depicts the situation of the heads.

Once correctly set-up, automatic execution of axis transformation is easy.

After compensating for the deviation of four quadrants, machining can be performed with higher precision.

ATC Options

Vertical Change Type and V&H Change Type **Auto Tool Changer**

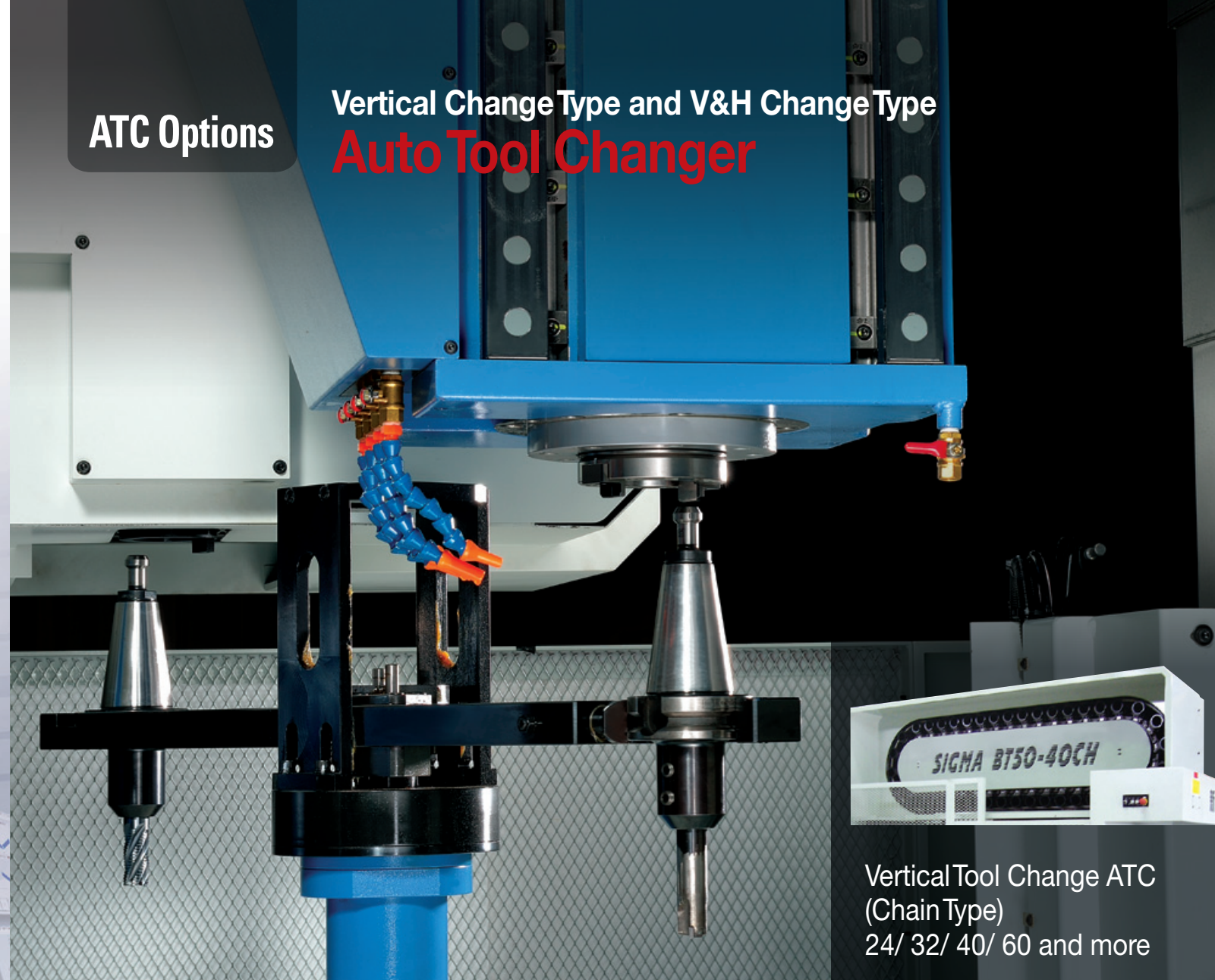

Vertical Tool Change ATC (Chain Type)
24/ 32/ 40/ 60 and more

Tool Dimensions

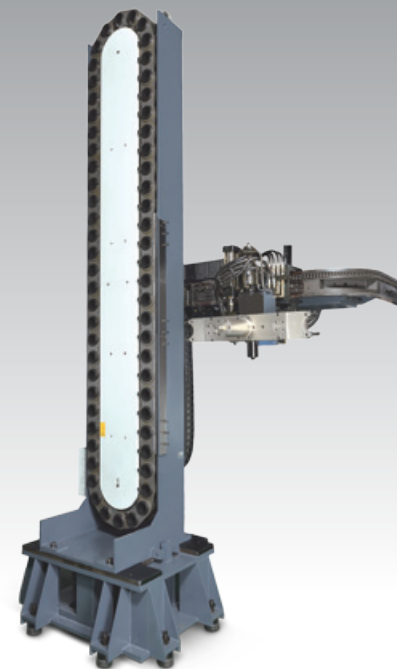
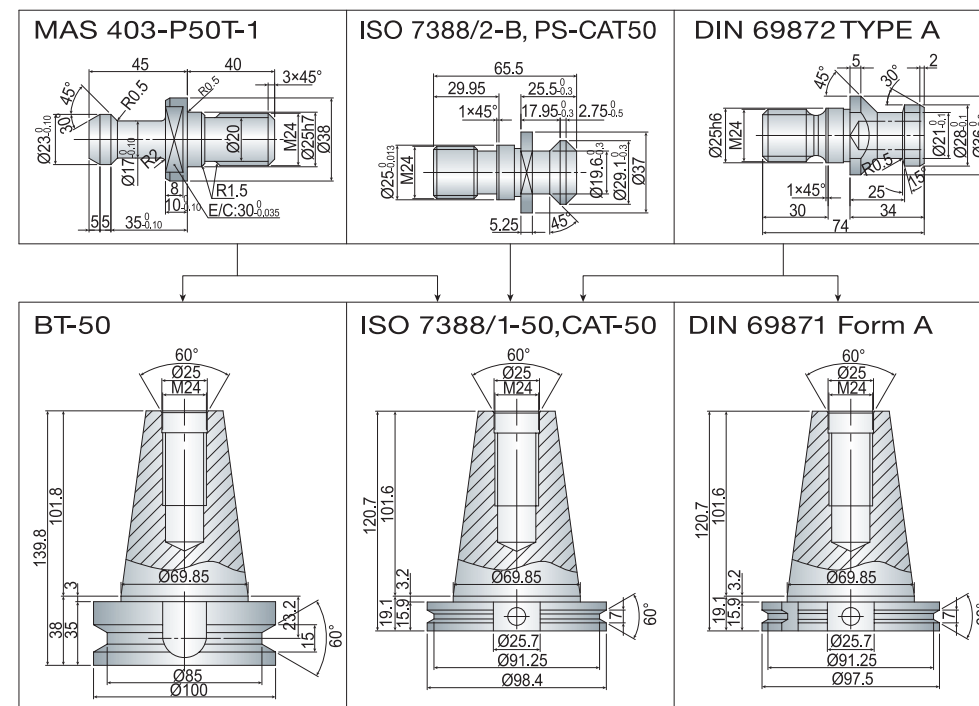

Vertical & Horizontal Tool Change ATC (Chain Type)
40/ 60/ 80/ 120 and more

Machine Layout

SCR-H Series Z-axis 4 Linear Guideways

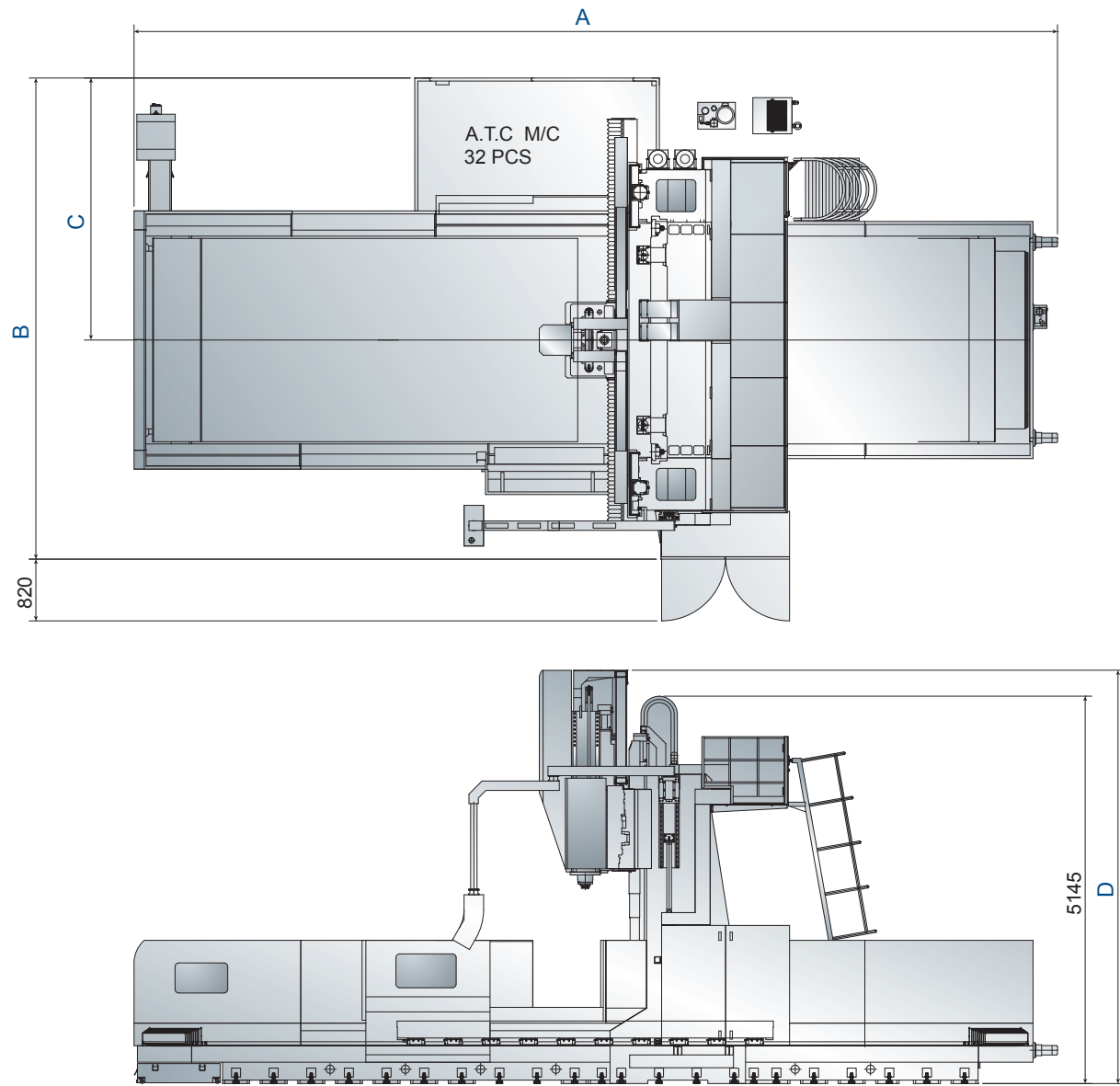
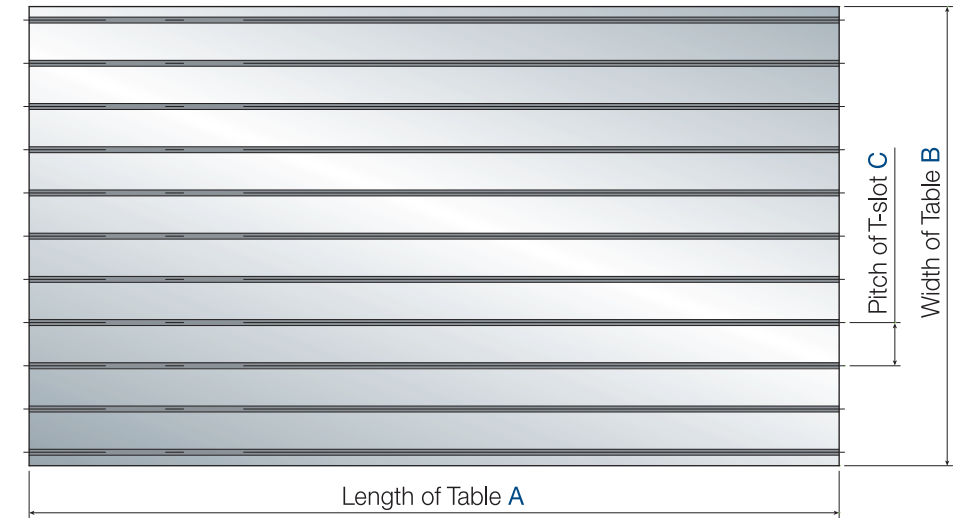
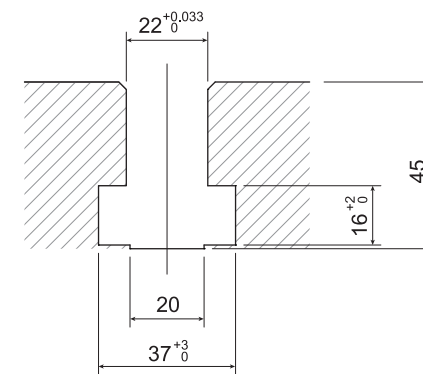

Table Dimensions



T-Slot Dimensions

Standard



Optional

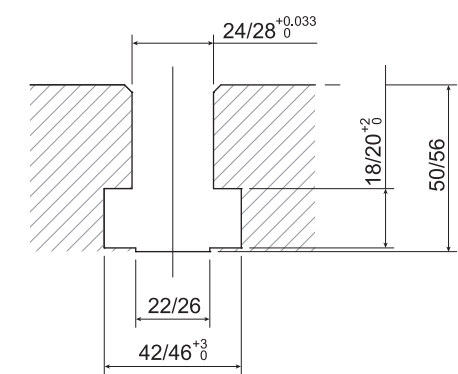

Model	SCR-3224H	SCR-3229H	SCR-4224H	SCR-4229H	SCR-4234H	SCR-4239H
A	8,270	8,270	10,270	10,270	10,270	10,270
B	5,960	6,460	5,960	6,460	6,960	7,460
C	3,265	3,515	3,265	3,515	3,765	4,015
D	5,140 / 5,490					

Model	SCR-5224H	SCR-5229H	SCR-5234H	SCR-5239H	SCR-6224H	SCR-6229H	SCR-6234H	SCR-6239H
A	12,270	12,270	12,270	12,270	14,570	14,570	14,570	14,570
B	5,960	6,460	6,960	7,460	5,960	6,460	6,960	7,460
C	3,265	3,515	3,765	4,015	3,265	3,515	3,765	4,015
D	5,140 / 5,490							

Model	Length of Table A	Width of Table B	Pitch of T-slot C	Amount of T-slot
SCR-3224H	3,000	2,200	200 X 10	11
SCR-3229H		2,700	200 X 12	13
SCR-4224H	4,000	2,200	200 X 10	11
SCR-4229H		2,700	200 X 12	13
SCR-4234H		3,200	200 X 15	16
SCR-4239H	5,000	3,700	200 X 18	19
SCR-5224H		2,200	200 X 10	11
SCR-5229H		2,700	200 X 12	13
SCR-5234H		3,200	200 X 15	16
SCR-5239H	6,000	3,700	200 X 18	19
SCR-6224H		2,200	200 X 10	11
SCR-6229H		2,700	200 X 12	13
SCR-6234H	6,000	3,200	200 X 15	16
SCR-6239H		3,700	200 X 18	19

SCR-H Series Z-axis 4 Linear Guideways

Note: 1. Brackets () denote optional specifications.
2. SIGMA CNC reserves the right to change the design and structure of any machine. This data is just for reference.
3. Custom machines available on request.

Item	Model	Unit	SCR-3224H	SCR-3229H	SCR-4224H	SCR-4229H	SCR-4234H	SCR-4239H	SCR-5224H	SCR-5229H	SCR-5234H	SCR-5239H	SCR-6224H	SCR-6229H	SCR-6234H	SCR-6239H	
X-axis Travel	mm	3,200			4,200				5,200				6,200				
Y-axis Travel	mm	2,400	2,900	2,400	2,900	3,400	3,900	2,400	2,900	3,400	3,900	2,400	2,900	3,400	3,900		
Z-axis Travel	mm	760 (1,000)								760 (1,000)							
W-axis Travel	mm	1,400								1,400							
Table Size	mm	3,000x2,200	3,000x2,700	4,000x2,200	4,000x2,700	4,000x3,200	4,000x3,700	5,000x2,200	5,000x2,700	5,000x3,200	5,000x3,700	6,000x2,200	6,000x2,700	6,000x3,200	6,000x3,700		
T-slots Dimension	mm	22 (24 · 28)								22 (24 · 28)							
Table Load Capacity	kg	10,000	12,500	15,000	17,000	19,000	21,000	17,500	20,000	22,500	25,000	25,000	27,500	30,000	32,500		
Distance Between Two Columns	mm	2,500	3,000	2,500	3,000	3,500	4,000	2,500	3,000	3,500	4,000	2,500	3,000	3,500	4,000		
Distance from Spindle Nose to Table	mm	0 ~ 1,800								0 ~ 1,800							
Spindle Taper, Tool Shank		ISO NO.50(40) BT-50 · CAT-50 · DIN 69871 · HSK-A100								ISO NO.50(40) BT-50 · CAT-50 · DIN 69871 · HSK-A100							
Spindle Speed Range	rpm	20 ~ 4,000 (30 ~ 6,000) (80 ~ 8,000) (100 ~ 10,000)								20 ~ 4,000 (30 ~ 6,000) (80 ~ 8,000) (100 ~ 10,000)							
Main Motor Output (30mins Rating / Cont.)	HP	30 / 25 (35 / 30)								30 / 25 (35 / 30)							
Rapid Traverse Rate X,Y axis	mm/min	10,000 (12,000)								10,000 (12,000)							
Rapid Traverse Rate Z axis	mm/min	12,000 (15,000)								12,000 (15,000)							
Cutting Feed Rate	mm/min	1 ~ 5,000 (1 ~ 8,000)								1 ~ 5,000 (1 ~ 8,000)							
Minimum Input Increment	mm/min	0.001								0.001							
Tool Magazine Capacity	pcs	(24 / 32 / 40 / 60)								(24 / 32 / 40 / 60)							
Max. Tool Diameter / Adjacent Empty Pockets	mm	Ø125 / Ø 210								Ø125 / Ø 210							
Max. Tool Length (from Gauge Line)	mm	350								350							
Max. Tool Weight	kg	(18 / 20)								(18 / 20)							
Tool Selection Method		ABS (Random Bi)								ABS (Random Bi)							
Tool Change Time (T-T) (approx.)	sec	11 (4.5)								11 (4.5)							
Power Requirement	kVA	60				65				75				80			
Floor Space Requirement	mm	11,200x7,700	11,200x8,200	13,200x7,700	13,200x8,200	13,200x8,700	13,200x9,200	15,200x7,700	15,200x8,200	15,200x8,700	15,200x9,200	17,500x7,700	17,500x8,200	17,500x8,700	17,500x9,200		
Machine Height from Floor Level	mm	5,140 (5,490)								5,140 (5,490)							
Machine Weight (approx.)	kg	40,000	44,000	46,000	50,500	55,000	59,000	63,500	69,000	74,000	78,000	77,500	83,500	87,000	91,000		
CNC Controller		Fanuc, Mitsubishi, Siemens, Heidenhain Series etc.								Fanuc, Mitsubishi, Siemens, Heidenhain Series etc.							
Positioning Accuracy	mm	JIS B6338 0.01/300 , VDI 3441 P0.035								JIS B6338 0.01/300 , VDI 3441 P0.035							
Repeatability Accuracy	mm	±0.005								±0.005							

Standard Accessories

- Lubrication System
- Glazed Window-type Splash Guard
- Screw-type Chip Conveyor
- Link-type Chip Conveyor
- Coolant Equipment
- Spindle Oil Cooler
- Z-axis Hydraulic Balance Unit
- Pneumatic Unit
- Chip Air Blower (by M-code)
- Work Lamp
- Auto Power-off
- M.P.G.
- Program End & Alarm Lamp
- Ethernet Interface
- Leveling Blocks & Bolts
- Toolkit
- Maintenance & Operation Manual
- Inspection List

Optional Accessories

- Auxiliary Table
- NC (Rotary Table, Index Table)
- 24/32/40/60 ATC Capacity
- Tool Presetter
- Auto Tool Length & Diameter Measurement
- Auto Probe System
- Linear Scale Feedback
- Coolant Through Spindle System
- Oil Hole Tool Shank Device
- Coolant Auto Air-Mist Device
- Manual 45°, 90° Angle Head, Universal Head, Extension Head, Swing Divided Angle Head
- Auto 45°, 90° Angle Head C-axis 5° (1°) by Gear Coupling, Auto Swing Divided Angle Head C & A-axis 5° (1°) by Gear Coupling
- Spindle Thermal Compensation
- Different Spindle Specifications Available

SIGMA CNC Technology Machinery Co., Ltd.

No. 53, Dazun Rd., Shengang Dist., Taichung City 42948, Taiwan

T +886-4-2562-8000 **F** +886-4-2562-1493 | 2563-3657

W www.sigmacnc.com.tw | www.sigmacnc.ecatalog.tw

E sigma.cnc@msa.hinet.net



Products

- CNC Double Column Machining Center
- CNC Double Column High Speed Machining Center
- CNC Double Column 5-Face Machining Center
- CNC Double Column 5-Axis Machining Center
- CNC Double Column Crossrail Machining Center
- CNC High Speed Horizontal Machining Center with APC
- CNC Moving Column Horizontal Machining Center
- CNC High Precision Grinding Machine



SIGMA CNC
We put innovation into practice